

Sensors for vibration acceleration, vibration velocity, vibration displacement FSA 084-xx

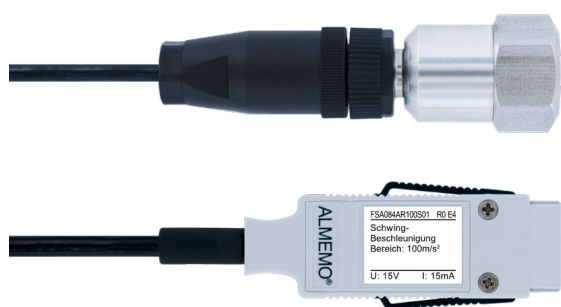

Vibration sensor FSA 084-xx with ALMEMO® connector

Technical data and functions

- Measurement of vibrations on bearings or housings for machine monitoring.
- The vibration is measured in the axial direction of the sensor in a defined frequency band.
- Different types for three measured variables:
 - Vibration acceleration (without integrator), particularly suitable for higher-frequency vibrations, e.g. on roller bearings or gears and for shocks.
 - Vibration velocity (integrator), particularly suitable for machine condition monitoring according to ISO 20816.
 - Vibration displacement (double integrator), particularly suitable for measuring the vibration amplitude on vibrating conveyors, vibrating screens and sifters.
- Suitable for use in harsh environmental conditions.
- Record vibrations as close as possible to their source. Flat coupling surfaces with low roughness are suitable. Rough cast surfaces or painted surfaces are unsuitable.
- Sensors comply with the specifications for vibration severity measuring devices according to ISO 2954, among others.
- Possible fields of application are:
 - Measurement of running smoothness on rotating machines and reciprocating machines in accordance with ISO 10816 / ISO 20816
 - Measurement of bearing vibrations according to VDI 3832
 - Measurement of vibrations in defined frequency bands

Measurements

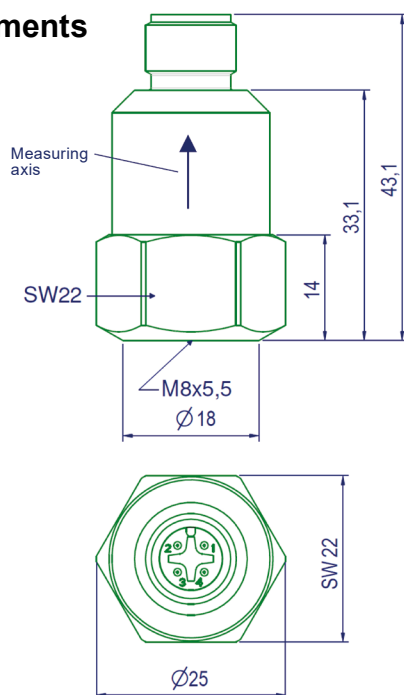

Explanation of terms

- RMS: Root mean square value
- Peak-to-peak: Full vertical length of the sine curve
- Integrator: Electrical circuit that integrates an input signal over time
- Vibration amplitude: Maximum distance that a vibrating object reaches from its center position
- Frequency band: Defined range of frequencies between the lower and upper limit frequencies
- Break acceleration: Load limit of the sensor, specified in g (acceleration due to gravity)
- Coupling surface: Surface to which the sensor is attached
- Roughness: Unevenness of the surface height
- Smooth running: Trouble-free running of a machine
- DIN ISO 2954: Standard „Mechanical vibration of reciprocating machines and of machines with rotating components - Requirements for vibration severity meters“
- ISO 10816 and ISO 20816: IEC standards for mechanical vibrations
- VDI 3832: VDI guideline for structure-borne noise measurements for assessing the condition of rolling bearings in machines and systems

Vibration

Technical Data:

Piezo system	Shear principle	4 mA offset drift over time (5000 h)	$\pm 1 \mu\text{A}$
Measured variable, nominal measuring range	see Variants	Dimensions	see drawing
Accuracy (for measured values > 1 % of measuring range end value)	2 % of final value	Mass without cable	60 g
Nominal temperature	23 °C	Housing material	stainless steel
Lower limit frequency	see Variants	Connection direction	axial
Upper limit frequency	see Variants	Mounting	Threaded hole M8 x 5.5
Settling time	5 s	Degree of protection	IP68
Operating temperature range	-40 ... +100 °C	Breaking acceleration	$\pm 5000 \text{ g}$
Temperature coefficient of sensitivity	+0.015 %/K	Connection socket	M12, four-pin, male (Binder 713)
4 mA offset drift in the operating temperature range	$\pm 4 \mu\text{A}$	Output	4 ... 20 mA, 2-wire
		Supply voltage	15 V via ALMEMO® plug
		ALMEMO® connection cable	M12 coupling socket with 2 m PVC cable and ALMEMO® plug

11/2025 • We reserve the right to make technical changes.

Variants

Order no.

Sensor for vibration acceleration, range 1 to 100 m/s² rms, frequency band 1.5 Hz to 10 kHz, resolution 0.1 m/s², with cable and ALMEMO® connector

FSA084AR100S01

Sensor for vibration velocity range 1 to 40 mm/s rms, frequency band 10 Hz to 1 kHz, resolution 0.1 mm/s, with cable and ALMEMO® connector

FSA084VR40S01

Sensor for vibration displacement, range 1 to 40 mm peak-peak, frequency band 3 Hz to 300 Hz, resolution 0.1 mm peak-peak, with cable and ALMEMO® connector

FSA084D40S01